

PMT.101 | Indexing plungers

Rest position, SUPER-technopolymer body

INCH

SUPER
TECHNO
POLYMER

INOX
STAINLESS
STEEL

RoHS

PA

+266 °F
-22 °F

- 1
- 2
- 3
- 4
- 5
- 6
- 7
- 8
- 9
- 10
- 11
- 12
- 13
- 14
- 15
- RH
- Wrench icon

THREADED BODY

Glass-fibre reinforced polyamide based (PA) SUPER-technopolymer.

PLUNGER

Black-oxide hardened steel or AISI 303 stainless steel.
Suggested tolerance for matching hole = H7.

KNOB

High-resilience polyamide based (PA) technopolymer, black colour or RAL 3000 red colour (C6), matte finish.

SPRING

AISI 302 stainless steel.

LOCKING NUT (NTT)

Glass-fibre reinforced polyamide based (PA) SUPER-technopolymer.
Available also as accessory sold separately (see table NTT).

STANDARD EXECUTIONS

- **PMT.101-A:** black-oxide steel plunger, without locking nut.
- **PMT.101-AK:** black-oxide steel plunger, with locking nut (supplied not assembled).
- **PMT.101-SST-A:** AISI 303 stainless steel plunger, without locking nut, not magnetic.
- **PMT.101-SST-AK:** AISI 303 stainless steel plunger, with locking nut (supplied not assembled), not magnetic.

FEATURES AND APPLICATIONS

- Lightness and high mechanical resistance of the product.
- The SUPER-technopolymer threaded body of the plunger offers a low friction factor to the plunger stroke; no lubricating maintenance is required.
- Anticorrosive material: suitable even in the presence of liquid or humidity (PMT.101-SST).
- Resistant to several cleaning cycles with solvents and other chemical agents, for this reason they are suitable for applications as in the pharmaceutical or food industry.
- The stop toothing (for the rest position) made out of SUPER-technopolymer: no risk of seizure or wear.

ASSEMBLY INSTRUCTIONS

Make sure that no machining residues are left on the threaded hole for the assembly of PMT.101 indexing plunger (see fig. 1). Do not make any chamfering in the hole (see fig. 2).

SUPER-technopolymer product based on ELESA technology, dimensions according to GN 617 standards as agreed with Otto Ganter GmbH Co. KG.

ANOTHER STANDARD EXECUTION

PMT.100: indexing plungers without rest position.



ELESA Original design

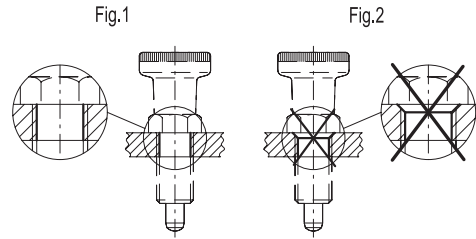

INCH

NTT

Code	Description
90301083	NTT-3/8-24
90301085	NTT-1/2-20
90301087	NTT-5/8-18

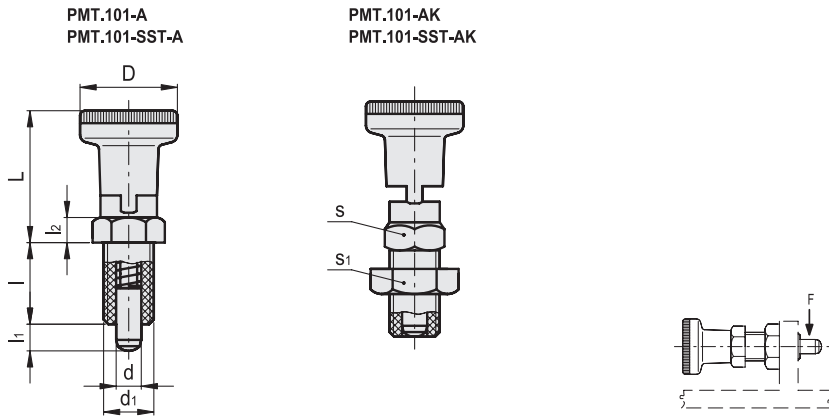

PMT.101

INCH

Code	Description	d-0.15-0.1	d1	L	D	l	l1	l2	s	s1	*	#	Maximum tightening torque [ft·lb]	Static load at breakage F [lbf]	⚖️
951601	PMT.101-5-3/8-24-A	0.2	3/8-24	1.14	0.83	0.67	0.2	0.2	0.47	-	2	4	4	515	0.03
951601-C6	PMT.101-5-3/8-24-A-C6	0.2	3/8-24	1.14	0.83	0.67	0.2	0.2	0.47	-	2	4	4	515	0.03
951602	PMT.101-6-1/2-20-A	0.24	1/2-20	1.38	0.98	0.79	0.24	0.24	0.55	-	2	5	7	784	0.04
951602-C6	PMT.101-6-1/2-20-A-C6	0.24	1/2-20	1.38	0.98	0.79	0.24	0.24	0.55	-	2	5	7	784	0.04
951611	PMT.101-8-5/8-18-A	0.31	5/8-18	1.69	1.22	1.02	0.31	0.31	0.75	-	2	7	13	1322	0.06
951611-C6	PMT.101-8-5/8-18-A-C6	0.31	5/8-18	1.69	1.22	1.02	0.31	0.31	0.75	-	2	7	13	1322	0.06
951621	PMT.101-5-3/8-24-AK	0.2	3/8-24	1.14	0.83	0.67	0.2	0.2	0.47	0.63	2	4	4	515	0.05
951621-C6	PMT.101-5-3/8-24-AK-C6	0.2	3/8-24	1.14	0.83	0.67	0.2	0.2	0.47	0.63	2	4	4	515	0.05
951622	PMT.101-6-1/2-20-AK	0.24	1/2-20	1.38	0.98	0.79	0.24	0.24	0.55	0.75	2	5	7	784	0.07
951622-C6	PMT.101-6-1/2-20-AK-C6	0.24	1/2-20	1.38	0.98	0.79	0.24	0.24	0.55	0.75	2	5	7	784	0.07
951631	PMT.101-8-5/8-18-AK	0.31	5/8-18	1.69	1.22	1.02	0.31	0.31	0.75	0.94	2	7	13	1322	0.11
951631-C6	PMT.101-8-5/8-18-AK-C6	0.31	5/8-18	1.69	1.22	1.02	0.31	0.31	0.75	0.94	2	7	13	1322	0.11

PMT.101-SST

INOX STAINLESS STEEL

INCH

Code	Description	d-0.15-0.1	d1	L	D	l	l1	l2	s	s1	*	#	Maximum tightening torque [ft·lb]	Static load at breakage F [lbf]	⚖️
951651	PMT.101-SST-5-3/8-24-A	0.2	3/8-24	1.14	0.83	0.67	0.2	0.2	0.47	-	2	4	4	403	0.03
951651-C6	PMT.101-SST-5-3/8-24-A-C6	0.2	3/8-24	1.14	0.83	0.67	0.2	0.2	0.47	-	2	4	4	403	0.03
951652	PMT.101-SST-6-1/2-20-A	0.24	1/2-20	1.38	0.98	0.79	0.24	0.24	0.55	-	2	5	7	650	0.04
951652-C6	PMT.101-SST-6-1/2-20-A-C6	0.24	1/2-20	1.38	0.98	0.79	0.24	0.24	0.55	-	2	5	7	650	0.04
951661	PMT.101-SST-8-5/8-18-A	0.31	5/8-18	1.69	1.22	1.02	0.31	0.31	0.75	-	2	7	13	986	0.06
951661-C6	PMT.101-SST-8-5/8-18-A-C6	0.31	5/8-18	1.69	1.22	1.02	0.31	0.31	0.75	-	2	7	13	986	0.06
951671	PMT.101-SST-5-3/8-24-AK	0.2	3/8-24	1.14	0.83	0.67	0.2	0.2	0.47	0.63	2	4	4	403	0.05
951671-C6	PMT.101-SST-5-3/8-24-AK-C6	0.2	3/8-24	1.14	0.83	0.67	0.2	0.2	0.47	0.63	2	4	4	403	0.05
951672	PMT.101-SST-6-1/2-20-AK	0.24	1/2-20	1.38	0.98	0.79	0.24	0.24	0.55	0.75	2	5	7	650	0.07
951672-C6	PMT.101-SST-6-1/2-20-AK-C6	0.24	1/2-20	1.38	0.98	0.79	0.24	0.24	0.55	0.75	2	5	7	650	0.07
951681	PMT.101-SST-8-5/8-18-AK	0.31	5/8-18	1.69	1.22	1.02	0.31	0.31	0.75	0.94	2	7	13	986	0.11
951681-C6	PMT.101-SST-8-5/8-18-AK-C6	0.31	5/8-18	1.69	1.22	1.02	0.31	0.31	0.75	0.94	2	7	13	986	0.11

* Spring preload
Spring maximum load



Indexing and positioning elements